	316	
	VEHICLE DETECTION	
	Stop-Line Radar Traffic Detector	

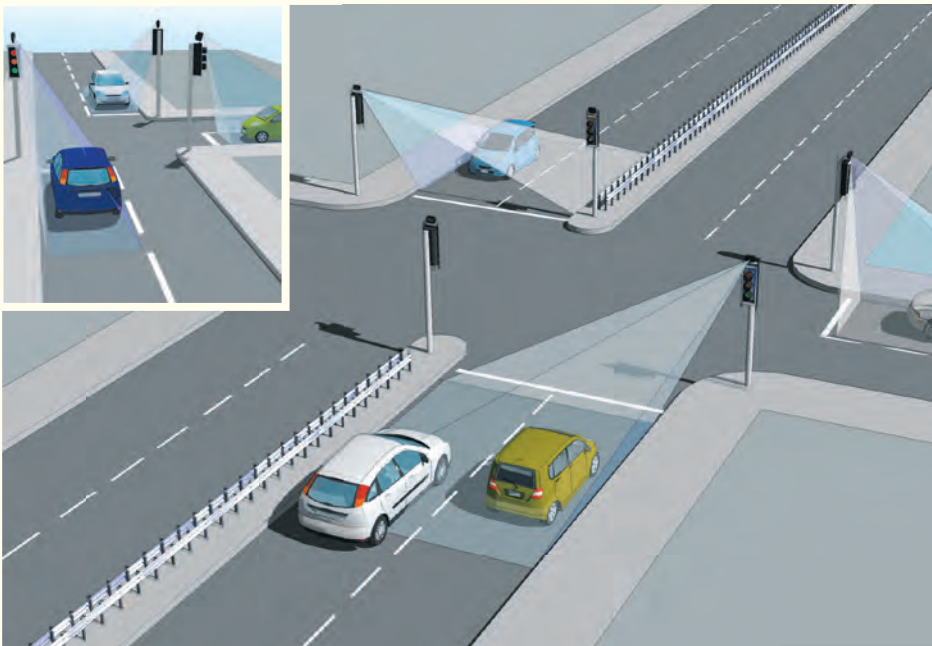

This product has been designed for the detection and monitoring of stationary vehicles at the stop-line of an intersection. The 316 FMCW radar operates in the 24GHz band. Approaching vehicles are tracked individually through the detection zone and will generate a detect state as they come to a stop.

- Non-intrusive vehicle stop-line radar detection
- Technically advanced detection platform
- Modern, compact stand-alone detector
- Dual, single and filter lane monitoring

STOP-LINE RADAR DETECTOR



FEATURES

- Detection of stationary vehicles at the stop-line
- Individual target tracking
- Bluetooth configurable via GUI
- User adjustable zone position
- 12Vdc/24Vac/dc or 230Vac supply options

DIMENSIONS:

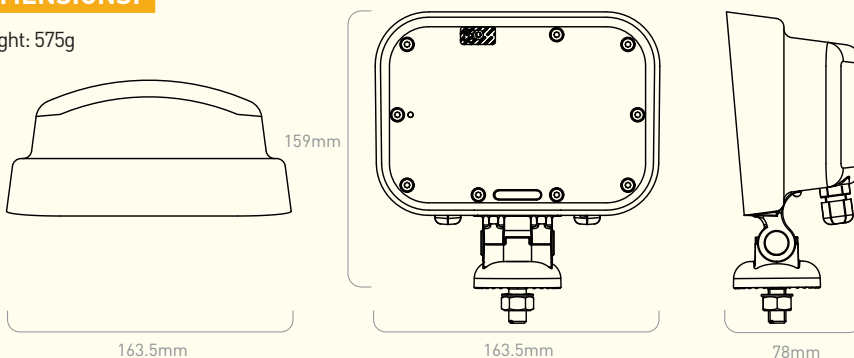

Weight: 575g



SPECIFICATIONS

Technology	FMCW Radar Technology
Detect Output	Opto-isolator
Mounting Height	3-5m nominal
Housing Material	Black polycarbonate
Sealing	IP65
Operating Temp	-30°C to +60°C
Power	1.9 - 2.1W @ 24Vac
Approved to:	ETSI EN 301489 BS EN 50293 ETSI EN 300 440 BS EN 60950 FCC (Part 15) AS/NZS 4268

316 TESTING PROCESS

	TEST EQUIPMENT:	HYPERION™	
	PRODUCT TEST:	315 316 335 336 342	
	TEST FUNCTION:	<ul style="list-style-type: none"> • True range simulation of target • Radar target processing optimisation • Test cycle time 9 minutes • Verification of communication protocols 	

Hyperion™ is a bespoke set of test equipment designed and developed by AGD Systems. It is dedicated to the testing of the AGD portfolio of 'ranging' FMCW vehicle radars. 100% of the 316 units manufactured at AGD are Certified by Hyperion.



FULL RANGE

HYPERION is dedicated to the testing of the AGD portfolio of 'ranging' FMCW vehicle radars. It provides true range simulation and both target speed and direction simulation at a given range

The key test functions performed by Hyperion to Certify the premium performance of your Intelligent Detection System are:

- True range simulation of target
- Target speed and direction simulation at a given range
- Radar target processing optimisation
- Transmitted radar power and frequency modulation measurement
- Radar signal to noise level measurement
- Verification of interface and communication protocols
- Test cycle time of 9 minutes

The radar test sequences performed by Hyperion on the radar under test provides a thorough examination of the performance of the 316 radar and specifically the ranging measurement capability provided by the FMCW technology deployed. This gives full control of simulated targets' signal size, speed, direction and range.

Verification of Bluetooth communication to the detector is verified during the test cycle.

Optimisation of frequency signals on Hyperion ensures full compatibility with country requirements within the 24GHz radar operating band.

LIFETIME PRODUCT TRACEABILITY

There are clearly defined pass and fail criteria at all stages within the Hyperion test process. The test results in association with the product build revision are recorded on a product serial number basis. The full suite of test measurements is instantly sent to the dedicated product database within the AGD secure server facility, providing full traceability during the product lifetime.

The AGD Certified symbol is your mark of assured performance.

AGD Systems Pty Ltd

14/252 New Line Road
Dural, NSW 2158
PO Box 402
Cherrybrook, NSW 2126

T: +61-2-96539934
E: sales@agd-systems.com.au
W: agd-systems.com.au

